

Pioneer Ditch Piping Installation Services

REQUEST FOR PROPOSAL

RFP NUMBER: WC1-058-2023-01

VENDOR MUST HAVE EXPERIENCE INSTALLING HDPE PIPE EQUAL OR GREATER THAN 16”

March 30, 2026



CONFIDENTIAL

Disclose and distribute solely relevant parties of The Nature Conservancy and Verde NRCD having a need to know and to potential vendors' employees with a need to know.

The Verde Natural Resource Conservation District (NRCD) and The Nature Conservancy in Arizona are soliciting proposals from construction vendors. Those receiving this Request for Proposal (RFP) are referred to as "Vendor." THIS IS NOT AN ORDER.

The Verde NRCD is a subdivision of the State Land Department functioning to promote the sustainable use and conservation of natural resources by facilitating technical and financial assistance to district cooperators. The NRCD is committed to conserving our ecological heritage through interactive promotion of educational activities and outreach.

THE NATURE CONSERVANCY (TNC) is a District of Columbia, USA, non-profit corporation with its principal place of business in Arlington, Virginia, USA. TNC has offices across the U.S. and in over 79 countries and territories around the world.

Background

The Nature Conservancy and the Verde Natural Resources Conservation District are soliciting proposals from qualified contractors to procure materials and construct irrigation infrastructure improvements for the Park Central Farm in Camp Verde, AZ. The project is based on the concept design prepared by Western Heritage Consulting & Engineering, dated March 23, 2026.

The work includes procurement and installation of approximately:

- 3300 ft of 24" DR32.5 HDPE pipeline
- ~20 ft of 30" DR32.5 HDPE pipeline
- ≤500 ft total of 15" and 18" HDPE pipelines
- Concrete diversion and inlet structures
- Multiple check and turnout structures
- Alfalfa valve assemblies and air vents
- Flow meter vault with ultrasonic flow meter system
- Associated grading, compaction, trenching, backfill, and surface restoration

The contractor will provide all materials, labor, equipment, and incidentals required to complete installation per the concept plans.

Scope of Work

The selected vendor will be responsible for:

- Review the concept drawings to verify quantities, installation requirements, elevations, and conflicts.
- Provide all materials specified on sheets C2.0, C4.0, C4.1, C4.2, and C4.3.
- Install all pipelines, structures, and appurtenances per design.

- Coordinate with Verde NRCD, TNC, and landowners for access and work sequencing.
- Restore any disturbed areas to pre-construction condition.
- Undertaking land preparation activities, encompassing the clearance of trees, shrubs, as well as the smoothing, leveling, and precise grading of the ditch. These efforts aim to align with the specified elevations articulated within the engineering design
- Fusion welding of pipes using a fusion machine provided by the Vendor.
- Installation of turnouts and structures in accordance with the detailed engineering design
- Backfilling of the pipeline that will be done using source fill and in accordance with engineering specifications, ensuring structural integrity and optimal functionality
- The RFP submittal will be based on the engineering 'concept plan', a final design will be provided to the selected vendor prior to construction, and associated changes in cost will be negotiated by all parties.

Technical Requirements

1. Detailed Technical Scope

1.1 Pipeline Installation

- Install 24", 30", 18", and 15" HDPE DR21 pipelines per plan alignments.
- Provide all fittings, valves, tees, reducers, and couplers
- Install thrust blocks at all vertical and horizontal angle changes.

1.2 Diversion & Inlet Structures (Sheets C4.0 & C4.1)

Construct:

- Concrete inlet structures connecting to existing 24" HDPE.
- Diversion weirs, steel check plates, and wing walls conforming to existing ditch geometry.
- Reinforced concrete walls
- Grout pipe penetrations as per details

1.3 Check & Turnout Structures

- Install structures shown on sheets C4.1.1–C4.1.3.
- Includes 12" headgates, bar grates, galvanized angles, embedded anchors.
- Provide lockable/tamper-proof hardware.

1.4 Alfalfa Valves, Air Vents & Risers (Sheet C4.2)

- Install all alfalfa valves, risers, service tees, reducers, and concrete pads.
- Install continuous air/vacuum relief valves per manufacturer recommendations.
- Follow details for OSHA trench slopes and compaction.

1.5 Flow Meter Vault (Sheet C4.3) (option)

In the proposal, please leave the flow meter as an option with associated cost.

Construct:

- Meter manhole structure with 21" PVC BO-rated pipe spool pieces.
- Install all components:
 - Flow meter
 - NEMA 4 enclosure
 - Battery enclosure
 - Solar panel
 - Communications antenna
 - Conduit
 - Ground rods
 - Air vents
- Contractor must submit meter specifications for approval prior to procurement.

1.6 Site Work

- Grading around structures for positive drainage.
- Temporary water bypassing if needed in coordination with stakeholders.
- Restore disturbed areas

1.7 Other Notes

- Access to the project site will be guaranteed via the easement on the Pioneer Irrigation Ditch through Hauser and Hauser Farm.
- To ensure an efficient and coordinated approach, The Nature Conservancy, the Verde NRCD, and the Vendor will collaboratively negotiate staging locations for pipes and materials, facilitating seamless project execution.
- Close coordination and collaboration between the Vendor and the project engineer are indispensable throughout the installation process. This partnership aims to ensure stringent compliance with engineering design flows, guaranteeing the pipeline's optimal functionality and performance upon completion.
- **All work must be completed by June 1, 2026.**

Submission Requirements

Interested vendors should submit the following:

1. Company profile and relevant experience
2. Detailed quote including costs for materials and installation
3. Timeline for completion of the project
4. Three (3) references from previous clients within the past three years with permission to contact
5. Any additional value-added services offered

Submission Deadline

All quotes must be submitted by Wednesday, April 22, 2026, by 5 pm MST to the following contact:

Alicia Peck

Alicia Peck Consulting, LLC

alicia@aliciapeckconsulting.com

Activity	Date(s)
Requests for Proposal published	Apr 4, 2026
Vendors submit Requests for Information	April 6 - April 10, 2026
Verde NRCD/TNC respond to Requests for Information	April 13-15, 2026
Proposals due to Verde NRCD/TNC	April 22, 2026
Vendor selected by Verde NRCD/TNC	April 24, 2026

Evaluation Criteria

Quotes will be evaluated based on:

1. Cost-effectiveness
2. Vendor experience and qualifications
3. Quality and reliability of procured materials
4. Proposed timeline
5. References and past performance

Terms and Conditions

This RFQ does not constitute a contract or an offer of employment. The issuing organization reserves the right to reject any and all quotes. Additional terms and conditions may apply and will be provided upon selection. Customers request firm fixed pricing. All materials submitted in response to this RFP will become the property of the Customer and may be returned only at the option of the Customer and at the expense of the Vendor. Successful and unsuccessful vendors will be notified in writing. The Customer shall not be obligated to detail any of the results of the evaluation.

The contents of submitted Proposals will be considered obligations of the successful Vendor. No information should be submitted that is not intended to be incorporated into the Proposal and any contract which may result from such Proposal. If there is any inconsistency between the terms herein and any of the other contract documents, the terms in the other contract documents shall prevail. Contractor must abide by all insurance requirements detailed in Attachment 3: The Nature Conservancy's Standard Contract for Services, Section

Additional Information

Any subcontractors must be identified along with the defined work they will perform. The Customer will not refuse a proposal based on the use of subcontractors but does retain the right to refuse the subcontractors selected. Vendor shall remain solely responsible for all subcontracted work. Describe your rationale for using subcontractors.

Confidentiality

All information provided in response to this RFQ will be kept confidential and used solely for the purpose of evaluating the proposal.

Attachments

The following items should be reviewed prior to submission. All forms should be completed and included with submission.

1. Equipment/Product, Service and Pricing Survey
2. Engineering Design
3. The Nature Conservancy's Standard Contract for Services
4. ARPA Terms and Conditions
5. Forced Labor of Ethnic Uyghurs Exhibition
6. Boycott of Israel Disclosure

We look forward to receiving your quote.

Sincerely,

Chip Norton

Verde NRCD Supervisor

EQUIPMENT/PRODUCT, SERVICE AND PRICING SURVEY

Please answer all the following questions. A "yes" or "no" answer may suffice, but please add clarification where noted or where you consider appropriate. Note any attachments.

Product: Ordering, Service and Warranties.

1. State details on complete maintenance and service guarantees.
2. How long is the product guaranteed? Include or attach all details.

Billing/Reports:

1. What are the Vendor's payment terms and how often does the Vendor send out invoices?

Pricing/Contract

1. Please list all **net pricing** (after discounts) for the following:
2. List all additional costs, e.g. freight, surcharges, set up charges.
3. Specify length of time for which proposal is valid. This must be a minimum of **30** days.
4. Please state how long your prices will be guaranteed for this contract.
5. Please list invoicing requirements. Vendors must allow at least 45 days to receive payment once invoiced. Vendor must be willing to invoice each entity separately for different portions of the project.
6. Does the Vendor agree to use the Customer's attached contract? If not:

Review attached contract and express any concerns the Vendor has regarding its terms using the following conventions:

Agreed - where the terms are acceptable as stated.

Modification Proposed - where Vendor is unable to accept the terms as stated but will accept a modification of the terms. Vendor must provide: (1) the reason for its inability to accept the term as stated and (2) modified language, which would be acceptable.

Not Agreed - where the term is completely unacceptable and no modification is possible. Please state the reason why such a term is unacceptable.



103
3059.15
TBM 3rd Br At OHC PP
N=1282244.80
E=723567.60

Over Box

PROPOSED CHECK AND
TURNOUT STRUCTURE
RE: C4.1.1
T.O.S: 3072.5'
WEIR ELEV: 3070.5'
PIPE INVT: 3067'

IRRIGATION BORDER (TYP)

FIELD 2: BORDER
IRRIGATION 18 ACRES

FIELD 1: BORDER
IRRIGATION 14.4 ACRES

100
3081.63
TBM 1001 5th Br
N=1281423.88
E=728645.49

3300± FT OF 24" DR21 HDPE
20± FT OF 30" DR21 HDPE
LESS THAN 500 FT TOTAL OF 15" AND 18" HDPE

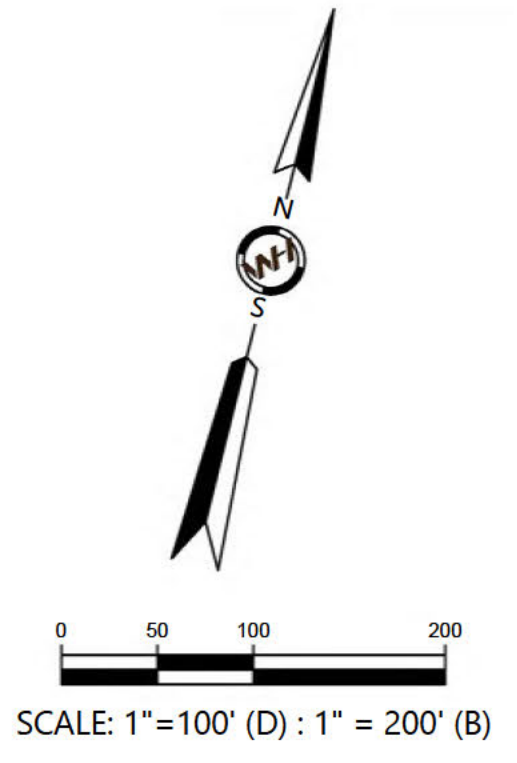

CONCEPT - NOT FOR
CONSTRUCTION

Rev	Date	Description
1.0	3/23/26	CONCEPT

By: DNH
Drawn By: SDG
Designed By: DNH
Reviewed By: RLA
Scale: 1"=100'(D)
1"=200'(B)

Job Number:
21WHC801.01

Sheet Number:
C2.0

WHL WESTERN HERITAGE
CONSULTING ENGINEERING
307.215.7430 1551 Three Crowns Dr. 104
info@westernhce.com Casper, WY 82604

OVERALL CIN MAP

CAMP VERDE, AZ T 13N R5E S16

P:\2026\Casper - WHCE, LLC 2665.00 - 2669 02\4652.D0 - TNC Parc Central Updated Design\CAD\DWG\21WHC801.01 PARC CENTRAL LAYOUTS.dwg C:\31511 MAP 1/22/2026 12:59:38 PM

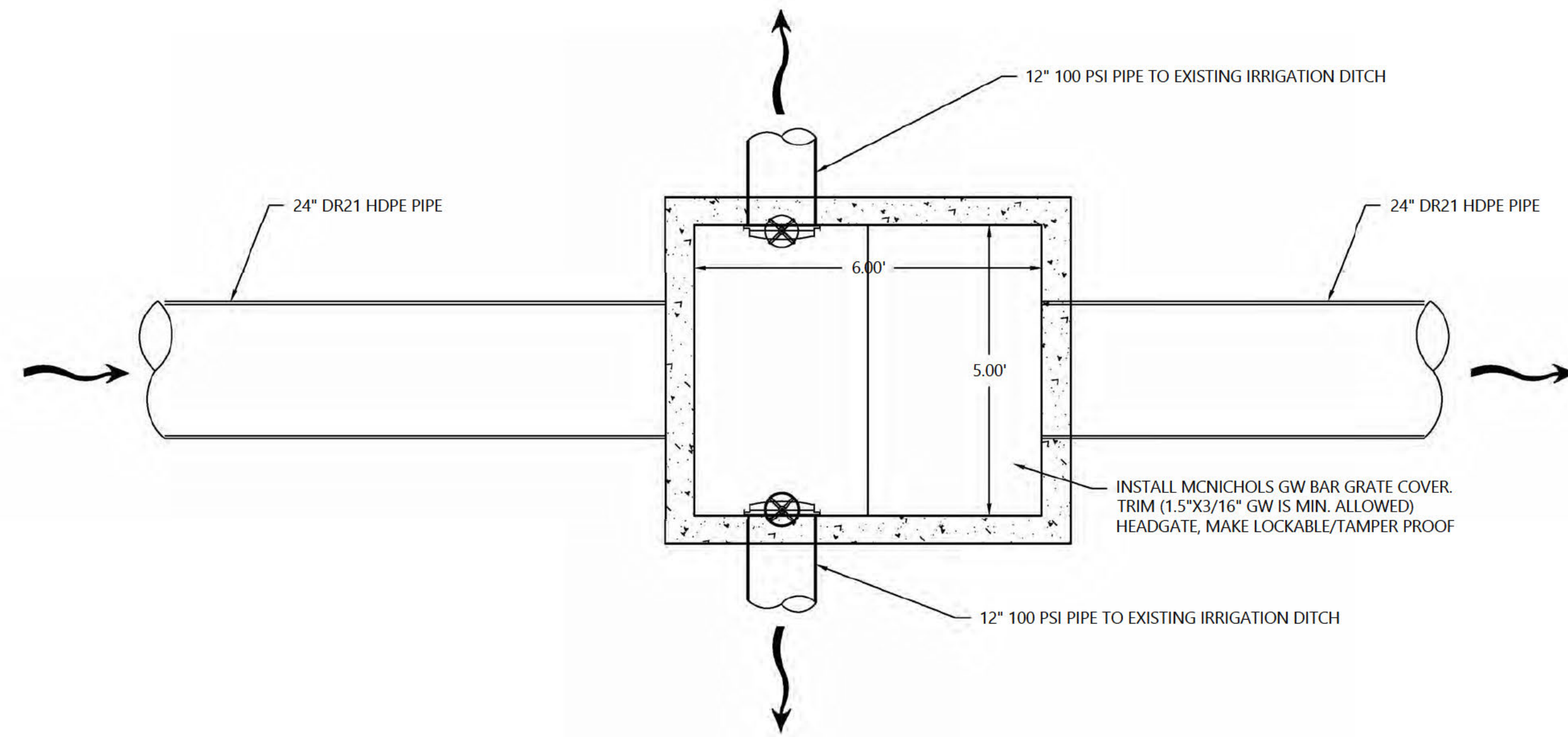

4.1.1 CHECK AND STURNOT STRUCTURE - PLAN
NTS

NOTE:
THIS IS TYPICAL SCHEMATIC FOR CHECK
AND DIVERSION STRUCTURE. SEE PLANS
FOR SPECIFIC LAYOUTS, DIMENSIONS,
AND ELEVATIONS.

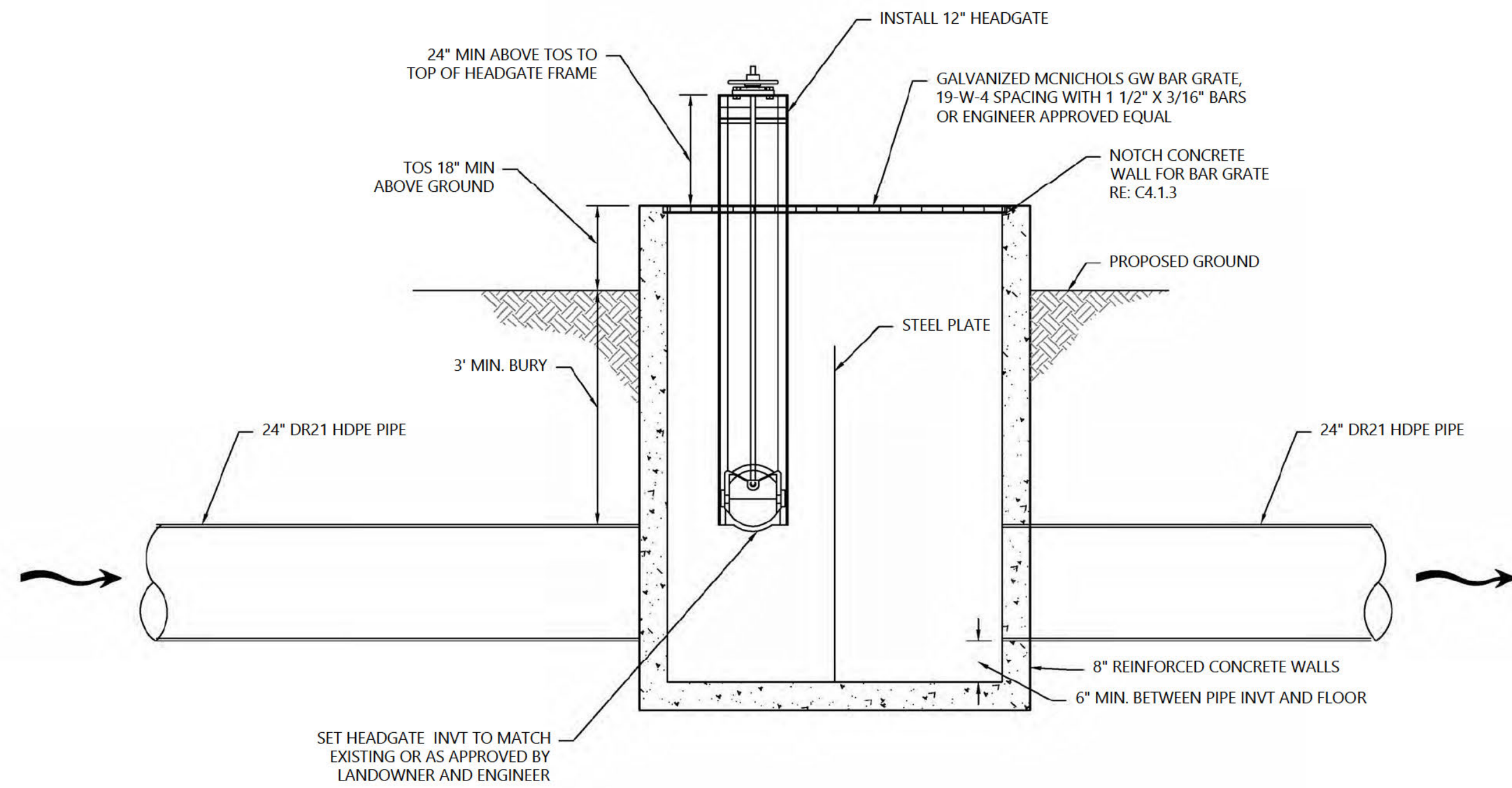

4.1.2 CHECK AND TURNOUT STRUCTURE - SECTION
NTS

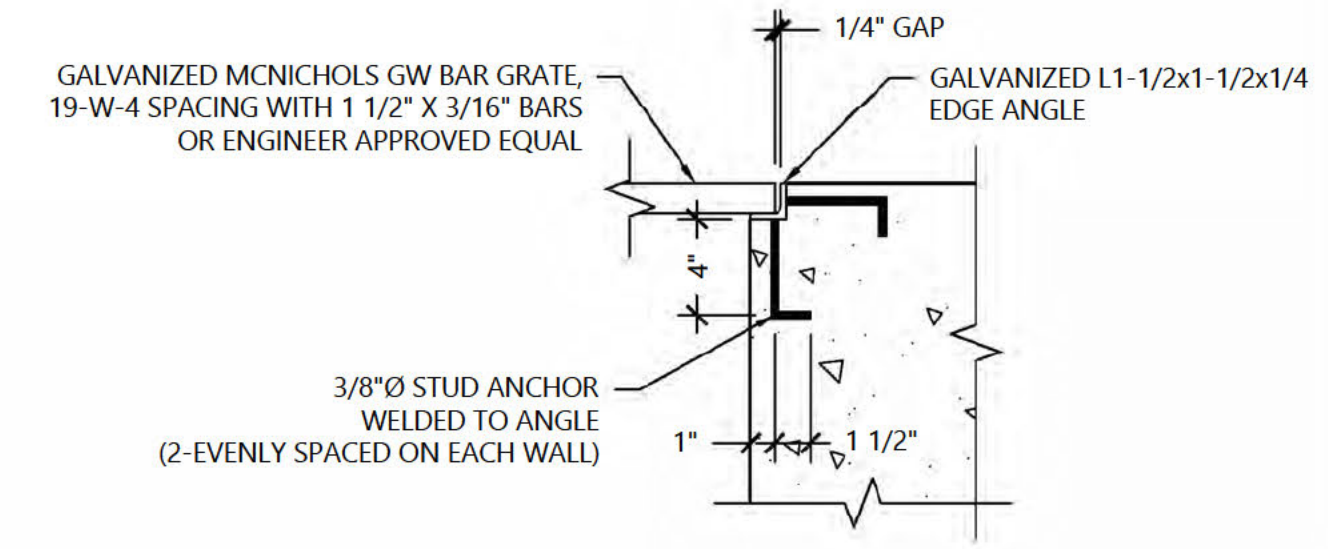

4.1.3 BAR GRATE ATTACHMENT
1 1/2" = 1'-0"

- NOTES:
1. SEE PLANS FOR LAYOUT AND PIPE DIMENSIONS.
 2. 8" REINFORCED CONCRETE WALLS, GRADE 60 REBAR GRID #5@12" O.C. MIN. CLEAR DIST. 2" ON VERTICAL WALLS AND 3" ON HORIZONTAL BASE.
 3. GROUT PIPE IN PLACE OR POUR IN PLACE. INSTALL GASKET O-RING/WATERSTOP AROUND PIPE WITH 4" OF PIPE EXTENDING BEYOND WALLS INSIDE STRUCTURE FOR PIPE EXPANSION/CONTRACTION DURING CONSTRUCTION. MAY BE TRIMMED AFTER PIPE HAS BEEN BURIED A MIN. OF 14 DAYS. GROUT WILL NEED TO BE REPAIRED IF DAMAGED BY PIPE MOVEMENT.

CONCEPT - NOT FOR
CONSTRUCTION

CHANNEL DIVERSION DETAILS
CAMP VERDE, AZ T 13N R5E S16

Rev	Date	Description	By	Drawn By	Title
1.0	3/23/26	CONCEPT	DNH	SDG	
				DNH	Designed By
				RLA	Reviewed By
					Scale: NTS

WHI WESTERN HERITAGE
CONSULTING ENGINEERING
307.215.7430 1551 Three Crowns Dr. 104
info@westernhce.com Casper, WY 82604

Job Number:
21WHC801.01

Sheet Number:
C4.1

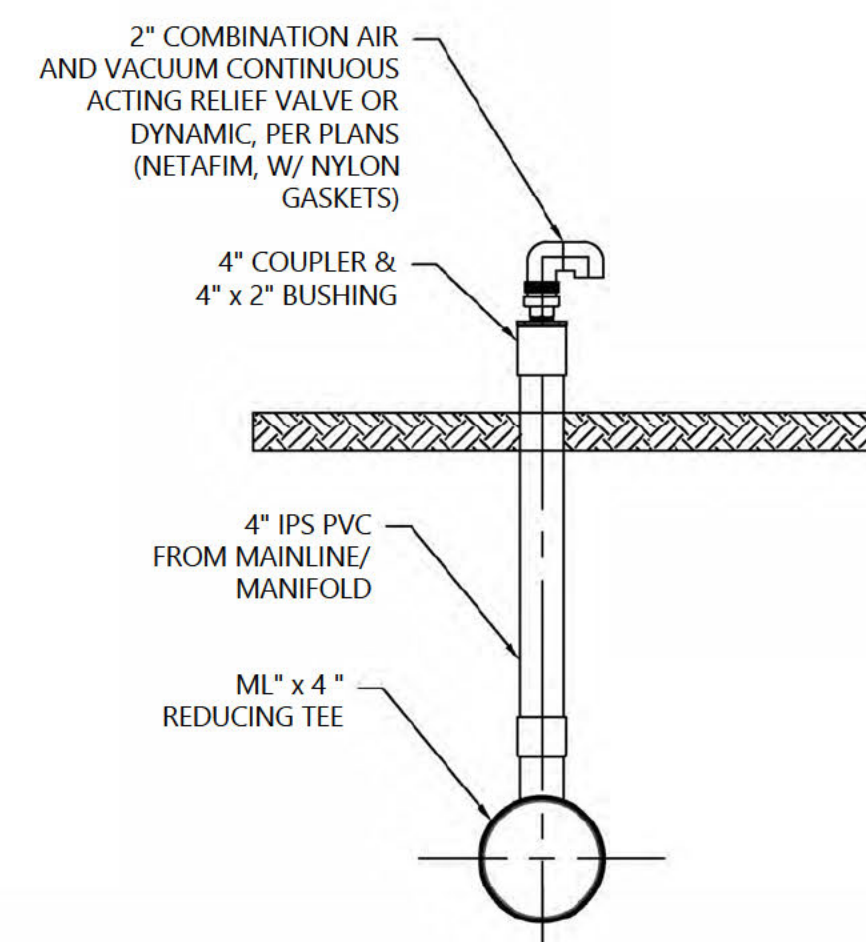

SINGLE DYNAMIC AIR VENT

N.T.S.

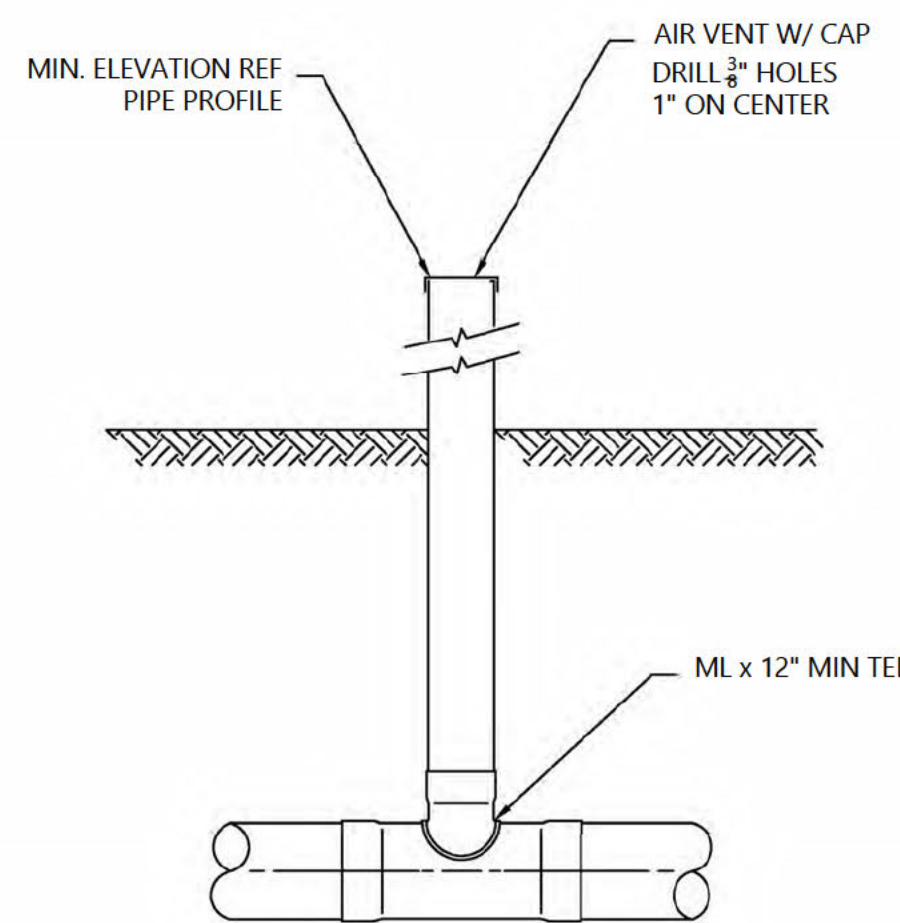

OPEN AIR VENT

N.T.S.

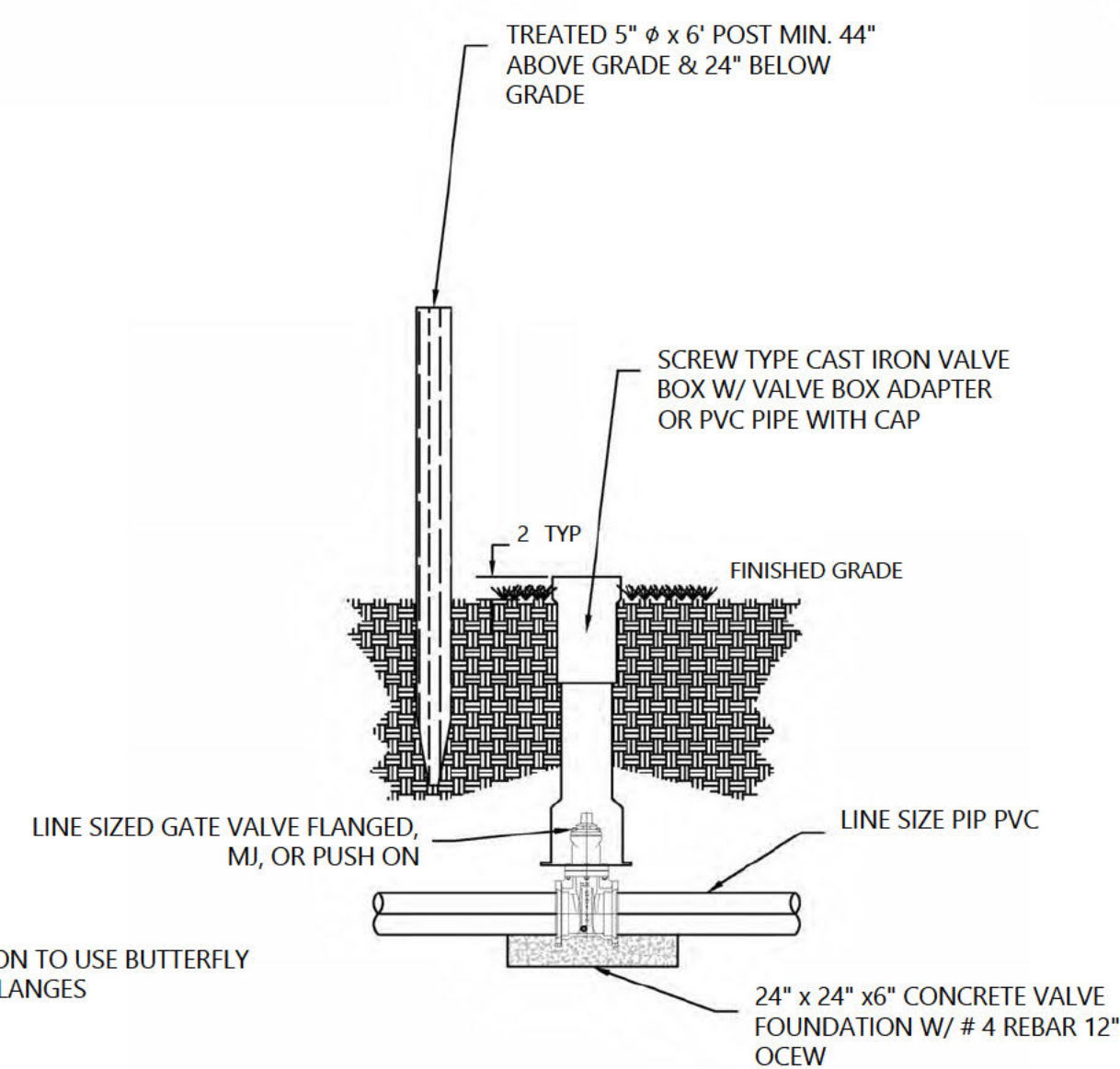

VALVE INSTALLATION DETAIL

N.T.S.

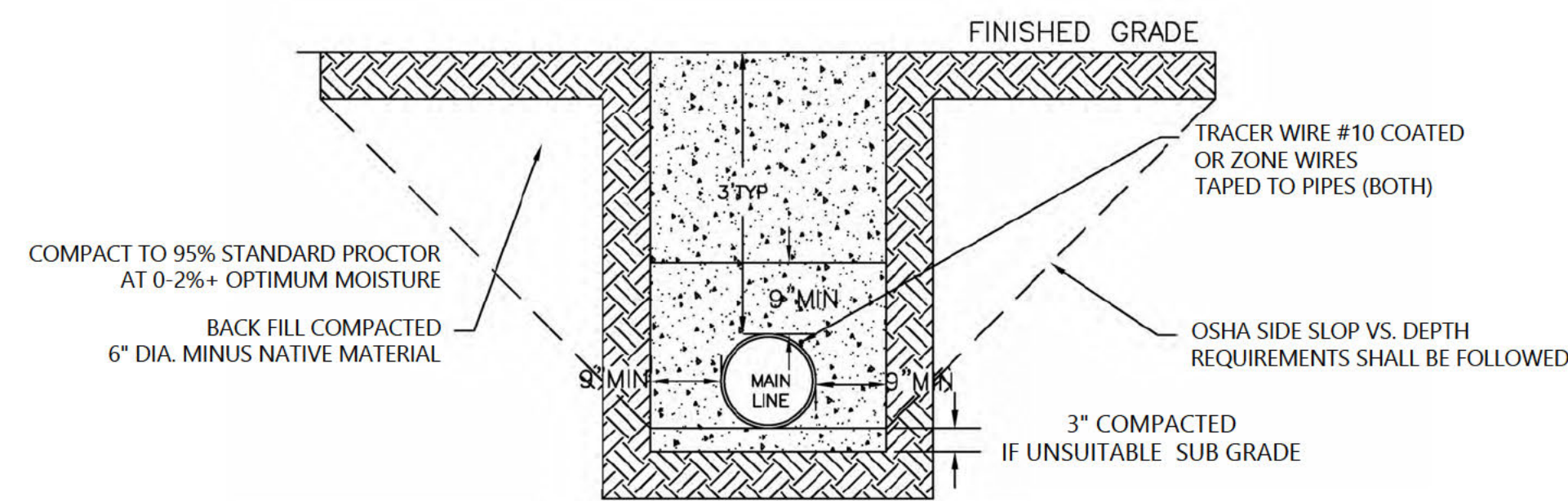

TYPICAL TRENCH SECTION

N.T.S.

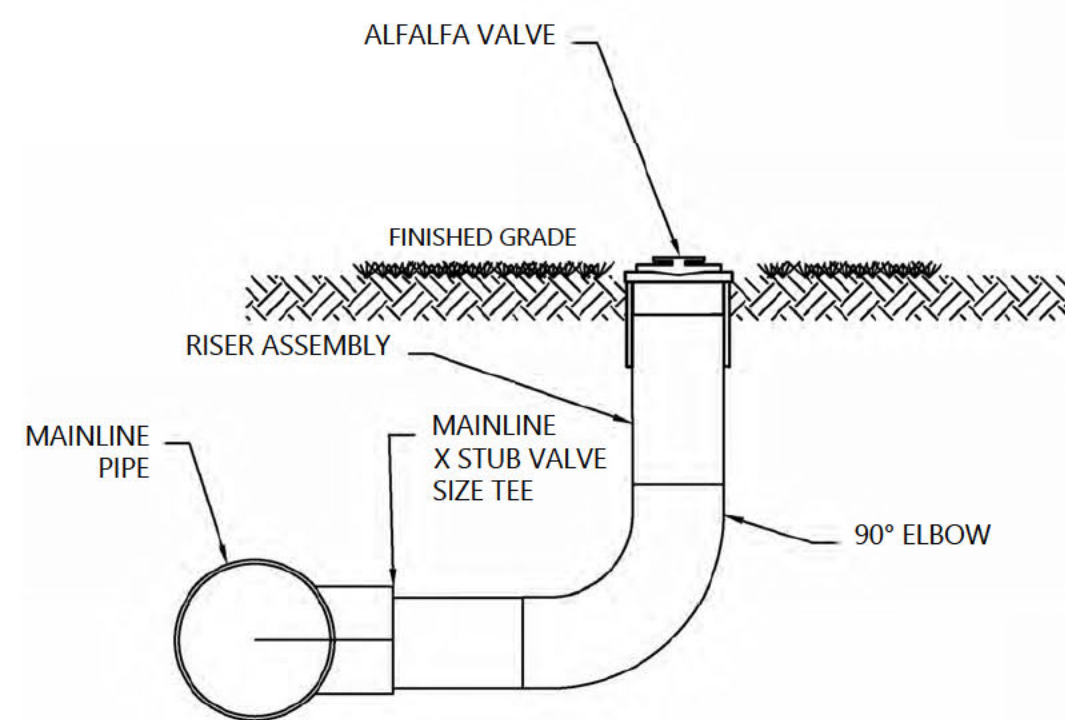

ALFALFA VALVE ASSEMBLY

N.T.S.

ALFALFA VALVE STATIONS	
1+36.29	12+98.15
1+74.98	13+48.46
2+17.02	14+46.76
2+69.55	15+28.38
3+11.58	15+68.40
3+64.12	16+18.42
4+06.16	16+58.44
4+57.83	17+08.48
4+98.33	17+48.51
5+49.23	17+98.56
5+89.99	18+38.64
6+40.02	18+89.24
6+80.03	19+29.73
7+30.06	19+80.33
7+70.09	20+20.81
8+20.11	20+71.42
8+60.13	21+11.90
9+13.75	21+62.51
9+57.79	22+03.02
10+11.56	22+53.66
10+52.68	22+94.17
11+04.11	23+44.81
11+44.40	23+85.32
11+94.61	24+35.96

SPRINKLER & SURFACE IRRIGATION

1. INSTALLATION AND MATERIALS SHALL MEET THE REQUIREMENTS OF NRCS PLANS STANDARDS AND SPECIFICATIONS #442 & 443 (SPRINKLER IRRIGATION, IRRIGATION SYSTEM-SURFACE).
2. ALL PIPE INSTALLED SHALL MEET THE REQUIREMENTS OF 430 IRRIGATION WATER CONVEYANCE STANDARDS AND SPECIFICATIONS. IF MATERIALS NOT COVERED IN 430 STANDARDS, MANUFACTURES PERFORMANCE DATA MUST BE PROVIDED PRIOR TO INSTALLATION.
3. ALL APPURTENANCES MUST BE APPROVED BY AUTHORIZED WHCE OR AUTHORIZED NRCS PERSONNEL PRIOR TO INSTALLATION AND MANUFACTURERS PERFORMANCE DATA MUST BE PROVIDED.
4. PUMPS, POWER UNITS, AND FILTERS SHALL BE INSTALLED ON A FIRM BASE.
5. PUMPS ARE RECOMMENDED TO BE INSTALLED ACCORDING TO NRCS PLANS STANDARDS AND SPECIFICATIONS #533
6. PUMPS MUST BE PROTECTED FROM THE WEATHER, WITH THE MINIMUM PROTECTION BEING A SHADE STRUCTURE. A WELL VENTILATED ENCLOSURE IS RECOMMENDED. PUMP SHADE IS NOT REQUIRED.
7. ALL APPLICABLE LOCAL, STATE, AND FEDERAL RULES AND REGULATIONS SHALL BE FOLLOWED DURING INSTALLATION, CONSTRUCTION, AND OPERATION OF THE SYSTEM.
8. ALL ELECTRICAL PERMITS ARE THE RESPONSIBILITY OF THE OWNER & ELECTRICAL CONTRACTOR.
9. PIVOT NOZZLE PACKAGES AND POWER DEMAND SHALL BE SUBMITTED FOR REVIEW AND PRIOR TO ORDERING OF PIVOT AND COMPONENTS.
10. ELECTRICAL SUPPLY, PHASE CONVERSION, PUMP CONTROLS, VARIABLE FREQUENCY DRIVES, CIRCUITS, AND PUMP PROTECTION SHALL HAVE COMPONENT CUT SHEETS PROVIDED FOR APPROVAL AS WELL AS A CIRCUIT/ROUTING DIAGRAM SUBMITTED FOR APPROVAL.
11. REFERENCE #587, #442, #443, AND #441 FOR ADDITIONAL SPECIFICATIONS.

PIPELINES

1. INSTALLATION SHALL MEET THE REQUIREMENTS OF NRCS PLANS STANDARDS AND SPECIFICATIONS #430 (UNDERGROUND PIPELINE).
2. THRUST BLOCKS SHALL BE INSTALLED AT ALL ABRUPT CHANGES IN GRADE OR ALIGNMENT, EITHER VERTICAL OR HORIZONTAL..
3. ALL EXPOSED PVC SHALL BE CLEANED & PAINTED WITH 2 COATS OF EXTERIOR ACRYLIC LATEX PAINT.
4. ALL GRADES SHALL BE CONSTRUCTED AS SHOWN UNLESS CHANGES ARE APPROVED BY AN AUTHORIZED WHCE EMPLOYEE OR AUTHORIZED INSPECTOR.
5. ALL WORK SHALL BE CLEAN, SMOOTH AND NEAT, AND OF WORKMAN LIKE FINISH.
6. IF WATER TABLE EXISTS GRAVEL BEDDING SHALL BE INSTALLED AS APPROVED BY THE ENGINEER OR AUTHORIZED TECHNICIAN. ALL DIFFERING SITE CONDITIONS SHALL BE REPORTED TO AN AUTHORIZED WESTERN HERITAGE CONSULTING & ENGINEERING REPRESENTATIVE.
7. MINIMUM COVER SHALL BE AS PER NRCS CONSTRUCTION SPECIFICATION 430-DD AND TRENCH SECTION SHOWN ON PLANS AND IN DESIGN REPORT. NO ROCK GREATER THAN 10% OF PIPE SIZE SHALL BE PLACED WITHIN 6" OF THE PIPE AND NO ROCKS GREATER THAN 6" IN THE REMAINING FILL.
8. OPTIONAL COPPER TRACER WIRE SHALL BE SECURED TO THE TOP OF ALL UNDERGROUND PIPES, AND SHALL SURFACE AT ALL ENDS AND AIR VENTS. THIS WIRE SHALL BE CONTINUOUS OR HAVE AN APPROVED SPLICE. WIRE SHALL BE APPROVED FOR UNDERGROUND INSTALLATION WITH SPLICES INTENDED FOR UNDERGROUND INSTALLATION. VALVE CONTROL COMMON WIRE MAY BE USED AS A SUBSTITUTE TO TRACER WIRE.
9. MULTIPLE UTILITIES OR PIPES INSTALLED IN THE SAME TRENCH SHALL HAVE PRIOR APPROVAL, AND HAVE MINIMUM SEPARATION AS REQUIRED BY THE UTILITY, LOCAL CODE, NRCS SPECIFICATIONS, AND/OR PRIOR APPROVED SEPARATION.
10. REFERENCE 430 FOR ADDITIONAL INSTALLATION REQUIREMENTS.

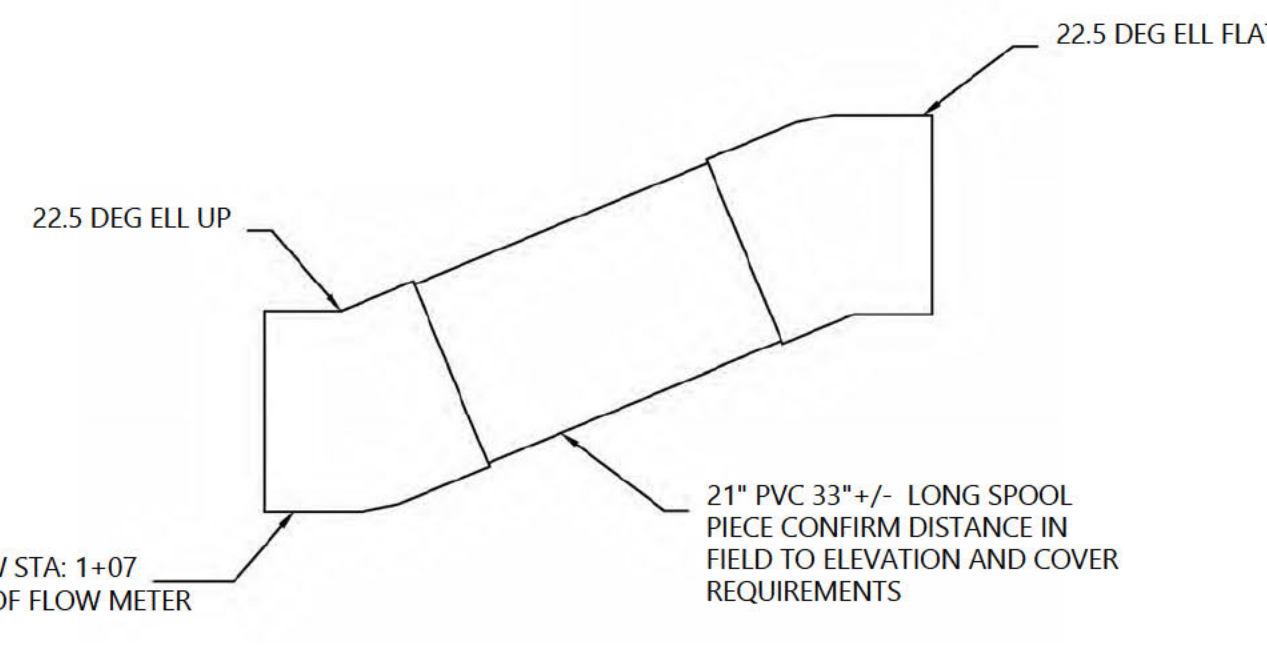

22.5 ELL UP & 22.5 ELL FLAT

N.T.S.

CONCEPT - NOT FOR CONSTRUCTION

PIPE DETAILS

CAMP VERDE, AZ T 13N R5E S16

Rev	Date	Description	By	Drawn By	Title
1.0	3/23/26	CONCEPT	DNH	SDG	
				DNH	Designed By:
				RLA	Reviewed By:
				NTS	Scale:

WESTERN HERITAGE CONSULTING & ENGINEERING
 307.215.7430 1551 Three Crowns Dr. 104 Casper, WY 82604
 info@westernhce.com

Job Number: 21WHC801.01
 Sheet Number: 4.2

P:\2026\Casper - WACE, LLC 2665001 - 26699 262652.DWG - TNC - TNC Central Updated Design\CAD\DWG\2026\21WHC801.01 PIPE DETAILS.dwg 4.2 PIPE DETAILS 3/23/2026 12:28:55 PM

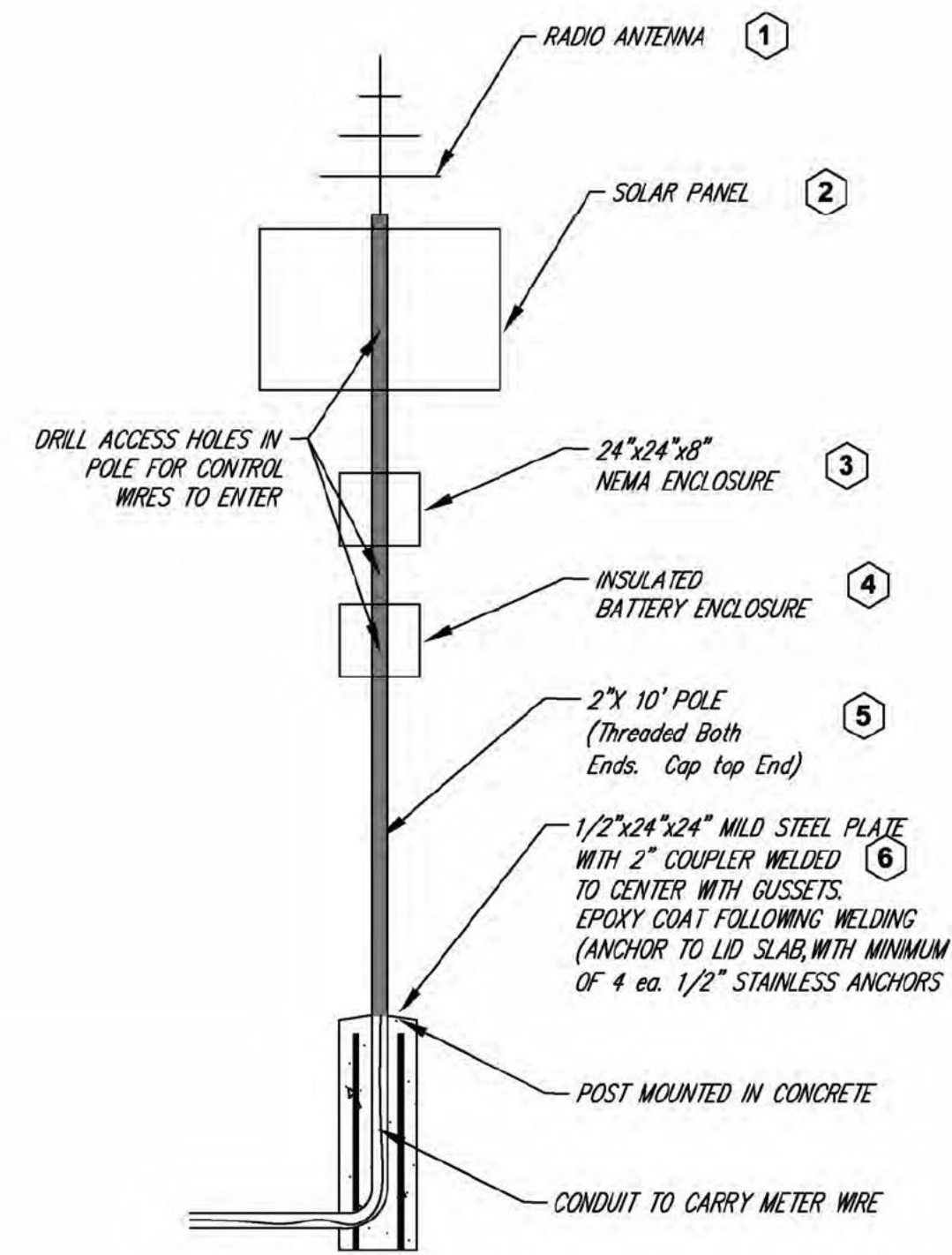

Parts Table	Description
1	Radio/Communication Antenna
2	Solar Panel - 24V DC
3	NEMA 4 Enclosure - for Readout and Communication Equipment Powder Coated or Stainless Steel
4	Insulated Battery Enclosure With Adequate Amp Hour Batteries
5	2"x10' Pole - Galvanized or Epoxy Coated
6	Steel plate - Galvanized or Epoxy Coated
7	Ultrasonic Flow Meter for 21" Pipe (SUBMIT SPECIFICATION FOR APPROVAL PRIOR TO INSTALLATION)

TRANSUDER CONTROL PANEL
NTS

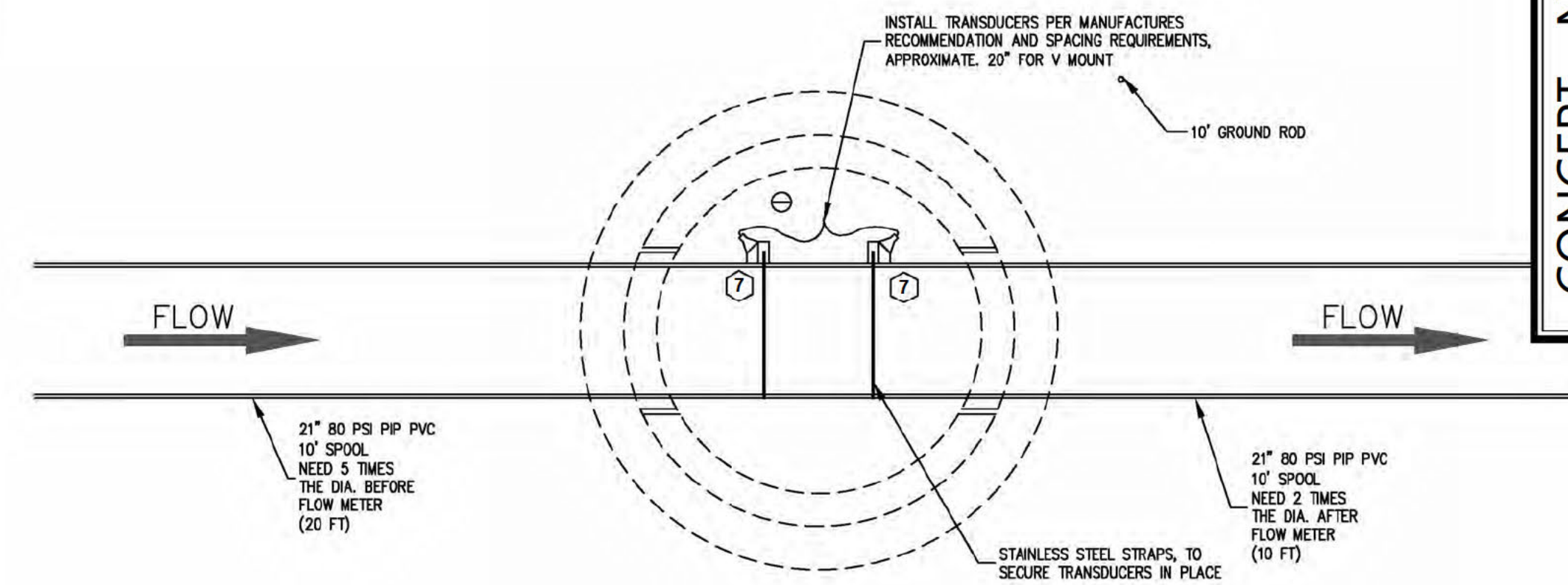

METER MANHOLE STRUCTER PLAN VIEW
NTS

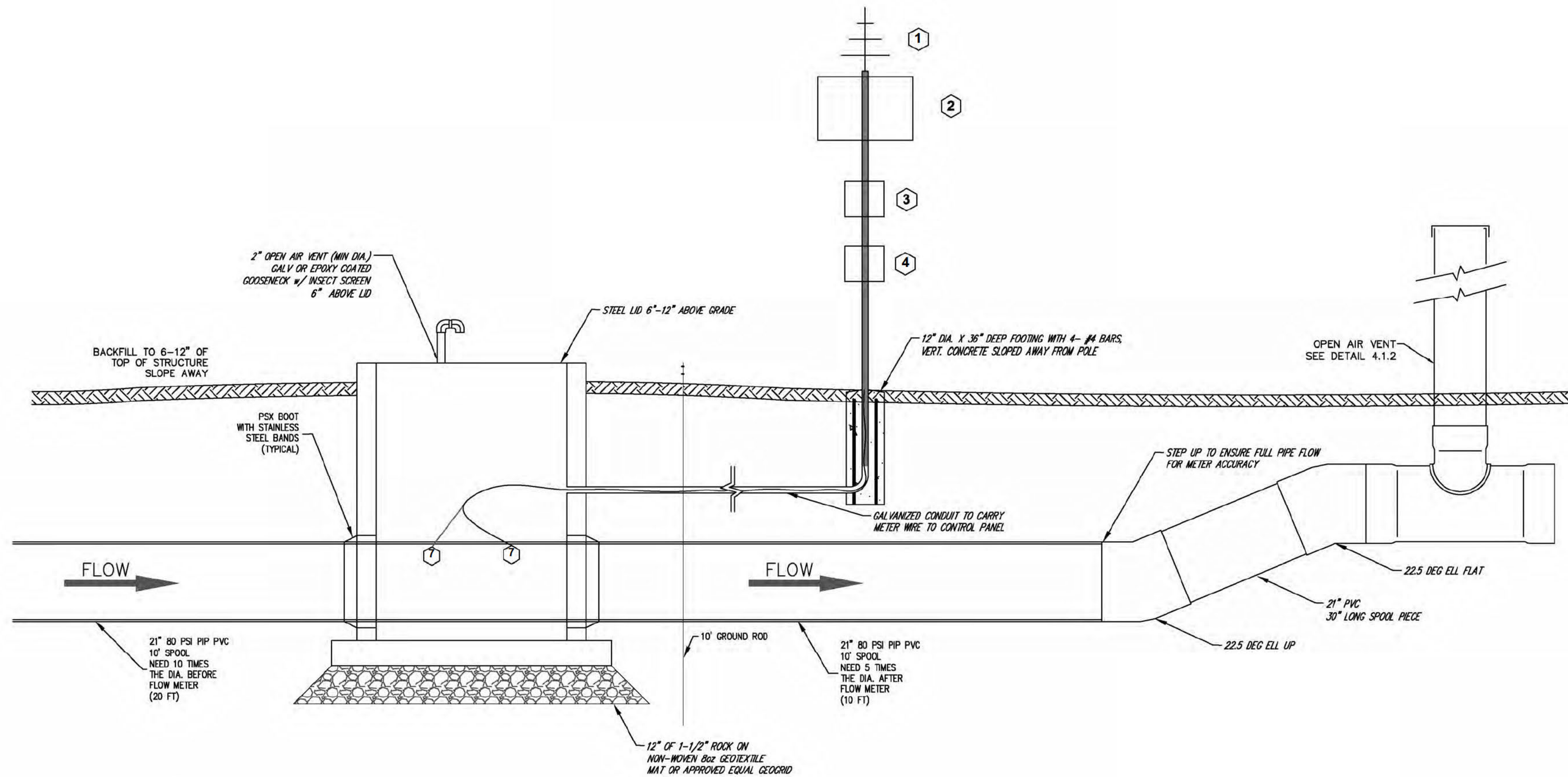

METER MANHOLE STRUCTER PROFILE VIEW
NTS

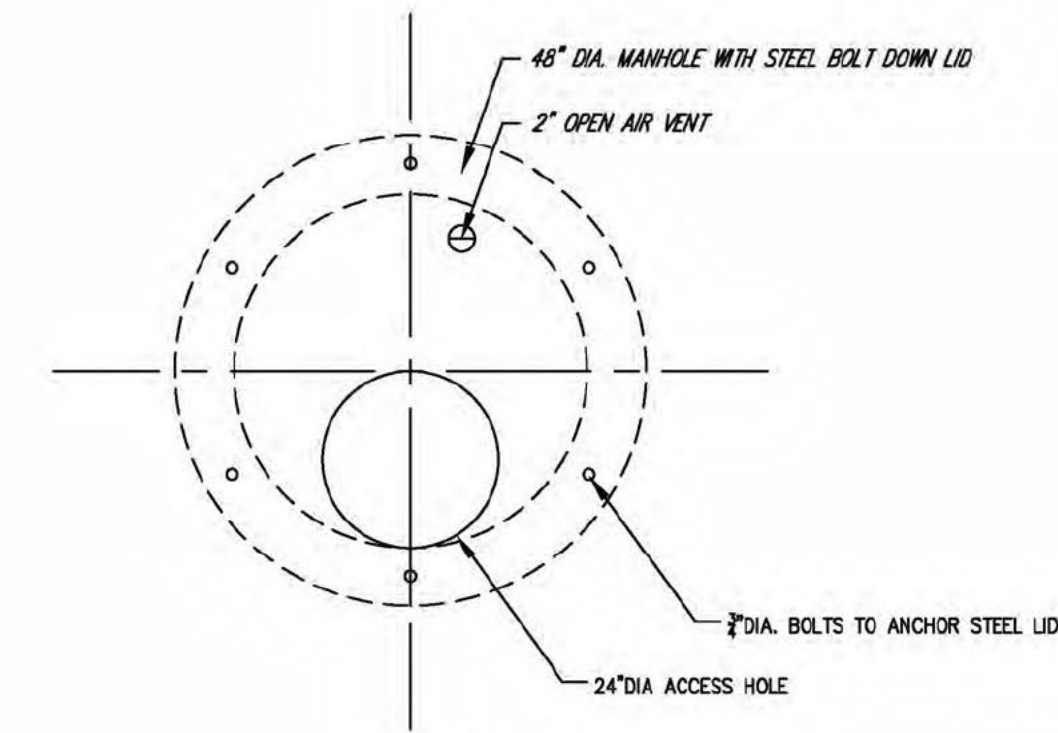

MANHOLE PLAN VIEW
NTS

- NOTE:
- METER VAULT TO BE FENCED FOR LIVESTOCK AND WILDLIFE EXCLUSION
 - PIPELINES WILL NEED TO BE PUMPED OUT DURING PERIODS OF NON-USE TO AVOID DAMAGE BY FREEZING TEMPERATURES.

CONCEPT - NOT FOR CONSTRUCTION

FLOW METER DETAILS
CAMP VERDE, AZ T 13N R5E S16

Rev	Date	Description	By	Drawn By	Title
1.0	3/23/26	CONCEPT	DNH	SDG	
				DNH	Designed By:
				RLA	Reviewed By:
				NTS	Scale:

WESTERN HERITAGE
CONSULTING ENGINEERING
307.215.7430 1551 Three Crowns Dr. 104
info@westernhce.com Casper, WY 82604

Job Number:
21WHC801.01

Sheet Number:
C4.3



Contract Number:	
TNC Accounting Information	
Project Name:	
Project-Award-Activity #:	
Source of funds:	<input type="checkbox"/> Public Funds <input type="checkbox"/> Private funds <input type="checkbox"/> Private funds with donor restrictions <input type="checkbox"/> Private funds as match for public funds

CONTRACT FOR SERVICES

This Contract for Services (the “**Contract**”) is entered into by and between **The Nature Conservancy**, a District of Columbia non-profit corporation (“**TNC**”), through the following U.S. office:

TNC Business Unit Name:	
TNC Business Unit Office Address:	
TNC Contact Name and Title:	
TNC Contact Email Address:	

and the following person or entity (“**Contractor**”):

Name of Contractor: (Include DBA, if any)	
Address:	
Telephone:	
Email Address:	
Name of Representative (if applicable):	
Type of Entity (if applicable):	
State of Incorporation (if applicable):	

1. **Services.** TNC engages Contractor to provide the services, goods and/or deliverables (collectively, the “Services”) described in **Exhibit A** (“Description of Services”) in accordance with the terms and conditions of this Contract.
2. **Payment.** TNC will compensate Contractor for the Services by paying a “Contract Fee” as follows:
 - a. **Contract Fee Amount** (inclusive of all taxes; exclusive of reimbursable expenses): US \$ [\$\$\$\$]
 - b. **Contract Fee Payment Schedule:**
 - i. US \$ [\$\$\$\$] - Payment One upon receipt and approval by TNC of Product [#].
 - ii. US \$ [\$\$\$\$] - Payment Two upon receipt and approval by TNC of Product [#].
 - iii. US \$ [\$\$\$\$] - Payment Three upon receipt and approval by TNC of Product [#].
 - iv. [Add additional payments as necessary]
 - c. **Reimbursable Expenses:** Contractor agrees to furnish (or reimburse TNC for) all tools, supplies, and materials to accomplish this Contract, and shall incur all expenses associated with performance, except as expressly provided herein. TNC may reimburse the Contractor for specific eligible expenses as follows:
 - None. TNC will not reimburse the Contractor for any expenses.
 - TNC will reimburse the Contractor for the following eligible expenses up to a maximum amount of US \$ [\$\$\$\$ Insert maximum amount here] (inclusive of all taxes): [Insert description of what expenses are eligible for reimbursement or write N/A. For example - Contractor’s out-of-pocket costs in performing the Services, such as economy travel (with automobile mileage at current U.S. Federal rate), accommodations, and workshop

materials. TNC shall not reimburse ordinary business expenses such as laptops, paper, ink, cell phone, internet, advertising, insurance, or overhead costs]

- d. **Invoices and Payments.** Unless additional acceptance criteria are defined in Exhibit A, TNC shall provide approval of Services and deliverables within 30 days of receipt. Requests for payment of the Contract Fee must be submitted to TNC in the form of an invoice itemizing the Services performed or delivered during the invoice period. Invoices will be subject to review and approval by TNC, and TNC may deny payment of requests received more than sixty (60) days after the final deadline for the completion of Services. TNC will make all payments either (i) by check, subject to TNC's receipt from Contractor of a properly completed IRS Form W-9, or (ii) via Vendor ACH, subject to Contractor's completion of TNC's Vendor ACH Enrollment Form. Expenses authorized for reimbursement by TNC must be: (i) substantiated by adequate documentation (such as receipts), unless waived in writing by TNC; (ii) reasonable in amount; (iii) related to and in furtherance of the Contract purposes; and (iv) submitted with Contractor's invoices for payment. In the event of early termination of the Contract and upon receipt of any termination notice, with or without cause, Contractor shall not incur any further expenses, without express written consent by TNC. TNC shall not pay any expenses to third parties on behalf of the Contractor.
3. **Term.** This Contract shall become effective upon the last signature date below and expires on [INSERT SPECIFIC EXPIRATION DATE] (the "Contract Term"). Any deadlines set forth herein may be extended only with TNC's prior written consent, which may be provided by email so long as they remain within the Contract Term. Time is of the essence in the performance of this Contract.
4. **Termination.**
 - a. **For Convenience.** TNC may terminate this Contract for convenience at any time upon two weeks' written notice to Contractor. TNC will pay Contractor for the Services that have been satisfactorily performed, as determined by TNC, as of the termination date. Contractor shall submit a final invoice within fourteen days following termination of services.
 - b. **For Default.** TNC may immediately terminate this Contract for default by written notice to Contractor if Contractor fails to provide satisfactory Services or deliverables, if the Services or deliverables cannot be performed in accordance with Applicable Laws (defined below) or TNC's policies, or if Contractor fails to perform any material duty, obligation, or covenant under this Contract, whether for circumstances within or beyond Contractor's control. Should termination occur as a result of Contractor's default, TNC may, without limiting any other remedies available to it under Applicable Laws, reduce the fees owed to reasonably account for unsatisfactory completion of the work, or recover damages from Contractor resulting from Contractor's default and offset any amounts payable to Contractor against such damages.
 - c. **Refund of Advanced Payments.** Regardless of the reason for termination, to the extent the balance of any advance payments made by TNC exceeds the total payments due to Contractor for Services satisfactorily completed, Contractor must promptly return the excess advance payments within fourteen (14) days.
5. **Conflict of Interest Determination.** Contractor represents and warrants that, to the best of Contractor's knowledge, the information Contractor has provided on TNC's Conflict of Interest Inquiry Form (attached as Exhibit B) is true and correct. If any of the information Contractor has provided changes during the term of this Contract, Contractor agrees to promptly notify TNC in writing of such change. The parties acknowledge that publicly traded companies engaging in the normal course of business, government agencies, and universities are not required to submit a Conflict Inquiry Form.
6. **Independent Contractor Status; No Benefits.**

The parties intend this Contract to create an independent contractor-client relationship and not an employee-employer relationship. Contractor is solely responsible for the conduct and control of the Services and fulfilling Contractor's duties and obligations under this Contract. Contractor is not an agent or employee of TNC, and no partnership, joint venture, or principal-agent relationship exists. Neither party will have any right, power, or authority by virtue of this Contract to create any obligation, express or implied, on behalf of the other party.
7. **Taxes.** Contractor is responsible for filing and paying its own taxes and for complying with the requirements of any applicable tax laws. TNC will not withhold or pay on behalf of Contractor or any of Contractor's employees any U.S. Federal, state, or local income tax, payroll tax, or any excise, sales, or use tax of any kind. TNC will report to the IRS on Form 1099 all fees paid to Contractor, as and to the extent required by Applicable Laws.

8. **Performance of Work.** Contractor represents and warrants that Contractor is qualified and will perform the Services in accordance with the highest standards of Contractor's profession or craft. Contractor is responsible for the complete performance of the Services notwithstanding the use of any subcontractors or work performed by anyone else under Contractor's direction or control. Contractor will not be paid for any Services found by TNC to be unsatisfactory.
9. **Liability; Indemnification.** Contractor agrees that it is entering into this Contract and performing the Services entirely at Contractor's own risk. Contractor, on behalf of Contractor and Contractor's employees, subcontractors, and agents, agrees to indemnify, defend, and hold harmless TNC and its directors, officers, employees, agents, and assigns (collectively, the "Indemnified Parties") from and against any and all liabilities, demands, damages, claims, losses, costs, settlements, judgments, fines, penalties, or expenses, including reasonable attorneys' fees and costs, (collectively, "Claims") that directly or indirectly arise out of, relate to, or result in any way from the performance of this Contract, (including but not limited to reclassification as an employee as describe above) whether or not the Claims have merit, involve third parties, or are caused or alleged to be caused by Contractor or any of the Indemnified Parties; provided, however, that Contractor will not be responsible for Claims arising from the sole negligence, gross negligence, or willful misconduct of any of the Indemnified Parties.
10. **Insurance.** Prior to commencing the Services and during the Contract Term, Contractor must have and maintain the following insurance policies: (a) workers' compensation insurance coverage as required by Applicable Laws; (b) commercial general liability insurance (including contractual liability if the Contract Fee is \$100,000 or more or if requested by TNC) of at least \$1,000,000 per incident, written on an occurrence basis, and covering the Services that are the subject of this Contract, including any related claims; (c) automobile liability insurance, covering all owned and non-owned vehicles used in performing the Services, with a liability limit of at least \$1,000,000 per occurrence; (d) professional liability insurance in the amount of at least \$1,000,000 if Contractor is providing professional services (such as consulting, engineering, design, appraisal, or surveying services); and (e) umbrella coverage of at least \$4,000,000 if the Contract Fee is \$100,000 or more, or if requested by TNC. Contractor's insurance policies must be primary to TNC's insurance policies. Before any of the Services commence, the foregoing requirements must be evidenced by one or more Certificates of Insurance, showing TNC as an additional named insured and requiring at least 30 days advance written notice to TNC of any cancellation, renewal, reduction in limits, or coverage or other material change of the policies. TNC reserves the right to request additional documentation, such as one or more policy endorsements, deemed reasonably necessary to ensure such requirements have been met.
11. **Work Product; Intellectual Property.** Contractor retains all right, title, and interest in works, inventions, and other intellectual property original to or owned by Contractor prior to the execution of this Contract or created outside the scope of this Contract. If the Services involve the creation of intellectual property including, but not limited to, inventions, concepts, processes, reports, derivative works, studies, photographs, software (including in both object code and source code form), drawings, designs, writings, related drafts, supporting materials, or data (collectively, the "Works"), TNC will own all right, title, and interest, including copyrights, and, if applicable, patent rights, in and to the Works. Contractor agrees that all copyrightable Works are "works made for hire" as defined under the copyright laws of the United States. To the extent that any of the Works are not works made for hire, Contractor unconditionally assigns to TNC and TNC's successors and assigns all right, title, and interest, including copyright, and other intellectual property rights, in and to the Works in all media (whether now known or later developed) worldwide and in perpetuity. Contractor grants to TNC a worldwide, non-exclusive, royalty-free, perpetual license to use, reproduce, distribute, modify, exercise, practice, perform, and exploit any assets subject to Contractor's patents, copyrights, or other intellectual property rights, to the extent that such license is necessary for TNC to enjoy all rights associated with ownership of the Works. Upon request of TNC, Contractor will deliver to TNC all tangible copies (including digital copies) of the Works and will execute and complete all documentation necessary to establish TNC's ownership of the Works. Contractor warrants and covenants that the Works will not infringe on the patent rights, copyrights, or other intellectual property rights of Contractor or third parties.
12. **Use of TNC Name and Logo.** Unless expressly authorized in writing in this Contract or in a separate written agreement, Contractor may not use TNC's name, logo, or other intellectual property in any manner, whether in conjunction with the Services or otherwise, except (a) to deliver invoices or other notices to TNC and (b) within acknowledgements of TNC funding, as authorized in writing by TNC.
13. **Confidential Information.** In performing the Services, Contractor might have access to information, whether verbal, in writing, in electronic format, or in any other tangible form, disclosed by TNC, directly or indirectly, to Contractor that is (a) identified as confidential, or (b) disclosed in a manner in which TNC reasonably communicates, or that Contractor should reasonably have understood, should be treated as confidential, whether or not designated as "confidential"

(collectively, "Confidential Information"). Confidential Information includes, without limitation, data sets, personal data (including donor data), marketing plans, research, products, technologies, software source code, software object code, data collection functionalities, trade secrets, pre-publication patent applications, research and development, know-how, and other information relating to TNC and its operations, programs, or systems. Contractor may not publish or divulge any Confidential Information without TNC's prior consent and agrees to use Confidential Information solely in furtherance of the Services. Contractor must use appropriate security procedures to safeguard Confidential Information. Contractor acknowledges and agrees that in the event Contractor receives any personal identifying information (i.e., information that identifies or can be used to identify an individual or that relates to an identified individual), Contractor (i) will be subject to a TNC IT Security review prior to such transfer or exchange and (ii) Contractor will comply with all Applicable Laws relating to the protection of personal identifying information. In addition, Contractor must comply with any additional requirements relating to protection of data as set forth in this Contract and/or as specified in any exhibits to this Contract.

14. **Compliance with Laws and other Safeguards.** Contractor represents, warrants, and agrees that Contractor:
- a. can lawfully work in the United States and/or the countries where the Services will be performed;
 - b. has or will obtain at Contractor's expense (except to the extent otherwise explicitly stated in this Contract) any permits, licenses, or authorizations required to perform the Services. This includes, without limitation, a property owner's prior permission to enter upon private property and any related permissions for completion of the project;
 - c. will take affirmative steps to inform TNC, prior to signing this Contract, if it is a privately held entity in which a Government Official¹ has equity ownership or, in the case of an individual person providing services as an independent contractor, if the Contractor is a Government Official for any government *other than* a U.S. local, state, or federal government agency;
 - d. will comply with all statutes, laws, ordinances, executive orders, rules, regulations, court orders, and other governmental requirements for the jurisdiction(s) in which the Services are performed and any other jurisdiction(s) in which Contractor is organized or authorized to do business;
 - e. will work with, and require all authorized subcontractors to work with, TNC to identify material risks and develop and implement appropriate environmental and social safeguards (e.g., consistent incorporation of free, prior, and informed consent) when and if the Services could directly impact Indigenous Peoples or Local Communities (IPLCs). Implementations plans must include periodic consultation with TNC;
 - f. will not employ any person who is less than 18 years old, unless permissible by applicable laws in the jurisdiction where the Contractor is performing the Services. Under no circumstances shall the Contractor employ any person who is less than 16 years old, *even if* permissible by the applicable laws;
 - g. will comply with all applicable anti-bribery or anti-corruption laws and regulations. To that end, Contractor shall not either directly or indirectly, pay, offer, promise to pay, or give anything of value (including any amounts paid by TNC) to any person, including an employee or official of a government, with the reasonable knowledge that it will be used for the purpose of obtaining any improper benefit or to improperly influence any act or decision by such person for the purpose of obtaining, retaining, or directing business. Any amounts paid by TNC to Contractor will be for services actually rendered in accordance with the terms of this Contract. Contractor shall not accept bribes or kickbacks in any form. The Contractor further represents, warrants, and agrees that it has not committed any of the acts prohibited herein or been accused of making or authorizing any acts prohibited herein;
 - h. will comply with all applicable counterterrorism, anti-money laundering and economic sanctions laws. To that end, the, Contractor represents and warrants that, to the best of Contractor's knowledge, Contractor and Contractor's subsidiaries, principals, and beneficial owners, if any:
 - i. are not presently debarred, suspended, proposed for debarment, or declared ineligible for the award of contracts by any government agency;
 - ii. (A) are not included on the Specially Designated Nationals and Blocked Persons lists maintained by the U.S. Treasury's Office of Foreign Assets Control, the United Nations Security Council Consolidated List, or similar lists

¹ For purposes of this Contract, TNC defines a "Government Official" as any official or employee of any government, political party, or public international organization, and any candidate for political office, regardless of whether the person purports to act in a private capacity or serves without compensation. For purposes of this definition, the "government" means any agency, department, embassy, instrumentality, or other governmental entity, including any company or other entity owned or controlled by the government.

- of proscribed entities identified as associated with terrorism; and (B) will not engage in transactions with, or provide resources or support to, any such individuals or organizations or anyone else associated with terrorism;
- iii. are not a person or entity with whom transacting is prohibited by any trade embargo, economic sanction, or other prohibition of law or regulation; and
- iv. have not conducted, and will not conduct, their operations in violation of applicable money laundering laws, including but not limited to, the U.S. Bank Secrecy Act and the money laundering statutes of any jurisdictions to which they are subject, and no action or inquiry concerning money laundering by or before any authority is pending;
- i. will comply with all applicable human rights laws, statutes, regulations, and codes as well as any human rights policy, standard operating procedure, guideline, or procedure adopted by TNC and shared with Contractor. Furthermore, in performing the Services, the Contractor shall respect human rights by: (a) identifying, preventing, and mitigating any potential or actual adverse human rights impacts resulting from its activities or the activities of its subcontractors, suppliers, or similar third parties; and (b) remediating any actual adverse human rights impacts which it causes or to which it contributes as soon as is practicable. Finally, the Contractor represents and warrants that neither Contractor nor any of its employees has been found at fault or penalized for any human rights violations or creating an adverse impact on human rights;
- j. will not discriminate against any individual or group based on race, religion, age, sex, national origin, citizenship, disability, sexual orientation, genetic information, or veterans/national guard/military reserve status. If any U.S. government funds are transferred under this Contract, Contractor is also subject to Title VI of the Civil Rights Act of 1964 and related statutes, which prohibit discrimination based on race, color, national origin, age, or disability in federally funded programs;
- k. if the Services involve new construction or alterations of existing structures or facilities, Contractor will ensure that the Services comply with the Americans with Disabilities Act (ADA), including the latest ADA Standards for Accessible Design and any other applicable accessibility requirements arising under federal, state, or local law;
- l. will not take any actions that might cause TNC to be in violation of the laws, statutes, regulations, or similar rules mentioned in this Section (collectively, "Applicable Laws");
- m. will immediately notify TNC in writing if any of the representations, warranties, certifications, statements, or agreements in this Section change before or during the Contract Term; and
- n. will include provisions at least as restrictive as these in all permitted subcontracts (except for subcontracts purchasing commercially available, off-the-shelf goods or services).

If TNC determines that any of the representations, warranties, certifications, statements, or agreements in this Section are false, no longer valid, or have materially changed, whether the Contractor is at fault or not, TNC may terminate this Contract effective immediately upon written notice to Contractor, with no further obligation by TNC under this Contract, including payment, and TNC may pursue all available remedies under Applicable Laws.

15. **Governing Law; Forum.** This Contract and claims relating to this Contract will be interpreted, construed, and governed by the laws of the state in which the TNC Business Unit set forth on the first page this Contract is located (excluding such state's choice of law principles, if any). In the event of any litigation over the interpretation or application of any of the terms of this Contract, litigation will be conducted in the state in which the TNC Business Unit set forth on the first page of this Contract is located.

16. **Miscellaneous Terms and Conditions.**

- a. **Notices.** Any notice, request, or demand made by either party to this Contract must be in writing and must be sent and deemed delivered as follows: (i) in person – delivered immediately; (ii) by mail, postage prepaid, certified (return receipt requested) – delivered three business days after sending; (iii) by a nationally recognized, next-day delivery service with tracking information and requesting next-business day delivery – delivered the next business day; or (iv) email – delivered the next business day.
- b. **Assignment; Subcontracting.** Contractor may not assign this Contract or subcontract any portion of the Services without TNC's prior written consent, which may be granted via email or by the inclusion of the subcontract description in Exhibit A. TNC's consent may be granted or withheld in TNC's sole discretion. In the event a subcontract is approved, Contractor agrees and warrants that: (i) each individual shall be properly classified as either

employee or subcontractor, (ii) it will ensure work is satisfactorily performed by said individuals, and (iii) it is fully responsible and liable for the satisfactory performance of all work performed hereunder. Contractor shall remain fully liable for all work by any subcontractors as if such services were performed by Contractor alone.

- c. **Code of Conduct; Helpline.** TNC expects itself and everyone with whom it does business to conduct themselves in ways that are consistent with its TNC’s Code of Conduct found at www.nature.org/codeofconduct. Anyone (whether an employee of TNC or not) may contact the TNC Helpline (anonymously, if desired) with questions, concerns, or suspected violations at www.nature.org/tnc Helpline.
 - d. **Entire Agreement; Amendments; Order of Precedence.** This Contract will become binding when signed by both parties and, together with its exhibits, which are hereby incorporated into and made a part of this Contract, constitutes the entire agreement between the parties and supersedes all prior or contemporaneous communications, both oral and written, between the parties relating to the Services described in this Contract. Unless explicitly stated otherwise in this Contract, no amendment to this Contract, including a change in the Description of Services, will be effective unless in a writing signed by both parties. In the event of a conflict, priority will be given to documents in the following order: (i) provisions in the main body of this Contract; (ii) provisions of any exhibit pursuant to Section 17 below, if applicable; (iii) Description of Services set forth in Exhibit A; and (iv) any additional exhibits or attachments to this Contract.
 - e. **Severability; No Waiver.** If any provision of this Contract is found to be invalid by a court of competent jurisdiction, the other provisions will not be affected by that finding. No delay in exercising any right or remedy under this Contract by either party will constitute a waiver of that right or remedy or of any other right or remedy under this Contract or under Applicable Laws.
 - f. **Joint and Several Liability.** If two or more persons or entities are identified as Contractor in this Contract, their obligations under this Contract are and will be joint and several.
 - g. **Counterparts.** This Contract may be executed in one or more counterparts, each of which will be deemed an original and all of which will constitute the complete Contract.
 - h. **Consent to electronic signatures.** Facsimile or scanned signatures on this Contract and any related documents, and digital or electronic signatures where authorized under Applicable Laws, will be fully binding for all purposes.
 - i. **Authorization to Sign.** Contractor represents and warrants that the person signing this Contract on behalf of Contractor is duly authorized to sign this Contract on Contractor’s behalf.
 - j. **Force Majeure.** This Contract may be immediately terminated by either party by providing written notice to the other party, and TNC shall pay Contractor for all Services that have been satisfactorily performed as of the date of termination, if acts of God, war, terrorism, widespread pandemics, or other similar circumstances make performance of the Contract illegal, commercially impractical, unsafe, or inadvisable.
 - k. **Survival.** The “Liability; Indemnification,” “Confidential Information,” and “Intellectual Property” Sections of this Contract will survive the expiration or earlier termination of the Contract.
17. **Additional Terms and Conditions.** This Contract is further subject to the additional terms and conditions set forth in the following Exhibit C (and subsequent exhibits, in the event more than one option is selected):

- Additional Service Terms and Conditions Exhibit
- Data Protection Agreement [\[Link\]](#)
- U.S. Government Laws and Regulations Exhibit [\[Link\]](#)
- State/Local Government Terms and Conditions Exhibit
- Private Funder Terms and Conditions [\[Link\]](#)
- Other: _____
- None

In consideration of the above, TNC and Contractor execute this Contract effective as of the later date of signature below.

The Nature Conservancy

[Contractor's Name]

By: (signature) _____
Print Name: _____
Title: _____
Date: _____

By: (signature) _____
Print Name: _____
Title (if applicable): _____
Date: _____

Exhibit A: Description of Services

Exhibit B: Conflict Inquiry Form

[Delete if not applicable; and add other Exhibits if applicable] Exhibit C: [Insert appropriate name from Section 17 above]

EXHIBIT A
Description of Services

EXHIBIT B
Conflict Inquiry Form

[DELETE EXHIBIT C IF NOT APPLICABLE (PER SECTION 17). CONSULT THE [DONOR-SPECIFIC STANDARD AGREEMENT CONNECT SITE FOR TEMPLATES](#)]

EXHIBIT C

[INSERT NAME AS DESCRIBED IN SECTION 17

REMEMBER – IF YOU ARE USING U.S. FEDERAL FUNDS – YOU MUST INCLUDE [THIS USG ATTACHMENT!](#)]

THIS IS AN ALTERNATIVE CLAUSE FOR SECTION 11 (INTELLECTUAL PROPERTY)

THIS IS NOT AN EXHIBIT - DELETE IF NOT APPLICABLE

This is an alternative IP Clause that may be appropriate for marketing, photography, and other creative contracts where the Contractor insists on retaining ownership of their work and providing a license to TNC.

You may use this alternative intellectual property clause if your agreement meets the following conditions:

- (1) Your Contract involves the creation of original photographs, images, graphics, illustrations, visual content, written works, recordings, audio-visual content, films and works of authorship, and your Contractor insists on retaining ownership of their works;
- (2) The license for TNC only covers *new Works* being created under this Contract. (If the license **only** covers *existing* materials and Contractor is neither creating any *new Works* nor performing any services (aside from providing the license to those existing materials), do not use this form, and please consult your attorney); and
- (3) The Works do not include the development of software, trade secrets, inventions (e.g., a process, method, machine, manufactured item, or composition of substances), branding, or Works that are intended to be sublicensed (including open source). If your Works include one of these items, consult your attorney first.

To use this clause, delete the default IP clause in the body of the contract and replace with this Section 11 (including subsections (a) through (f) as applicable).

Here is the link to the [Photo and Video Release Forms](#). Use these forms to obtain consent from individuals who appear in the photographs and videos taken by the contractor.

- 11. Intellectual Property.** The Contractor owns the copyright to all creative works it produces under this Contract (the “Works”). In consideration of the payments set forth in this Contract, Contractor hereby grants to TNC and its agents, related entities, successors, licensees, and assigns (collectively, “**Licensed Parties**”) a worldwide, perpetual, irrevocable, fully paid license to reproduce, modify, distribute copies of, publish, exhibit, publicly display, digitize, publicly perform, exploit, store, sublicense, prepare derivative works based upon, import, and otherwise use the Works (including without limitation any of their parts and elements) as frequently as the Licensed Parties in their sole discretion determine and in any manner or medium the Licensed Parties deem fit, including but not limited to TNC owned and operated social media properties, in any and all forms and media now known or hereafter created (the “**License**”).
- a. **Contractor Restrictions.** Although Contractor will retain the copyright ownership in the Works (subject to the license granted herein), the following restrictions to Contractor’s use of the Works apply: (i) Identifiable Individuals: Contractor agrees that Contractor will not use, nor will Contractor authorize or permit any third party to use Works (or any portion thereof) showing or depicting identifiable employees, officers, trustees, or board members of the Licensed Parties at any time unless Contractor obtains prior written consent from TNC. (ii) Model Release. If applicable, Contractor shall obtain the model release set forth in Exhibit C to this Contract (“**TNC Model Release**”), which is attached hereto and incorporated herein by this reference, from all identifiable persons who appear or are depicted or referred to in the Works. Contractor shall submit each TNC Model Release to TNC no later than fifteen (15) days after the Term of this Contract. (iii) TNC Property: Contractor agrees that it will not use, nor will Contractor authorize or permit any third party to use Works that contains the trademark(s), name(s), logo(s) or other proprietary materials of any of the Licensed Parties, without the prior written approval of the applicable Licensed Party.
 - b. **Third Party Use**: Contractor releases TNC from any and all liability associated with third parties’ unauthorized use of the Works.
 - c. **Representations and Warranties.** Contractor represents and warrants that: (i) Contractor is the exclusive owner of the entirety of the rights in the Works and that Contractor has full authorization and authority to enter into this Contract and grant the licenses herein; (ii) The Works (A) are Contractor’s original works of authorship, (B) are free of any claims of any nature and by any third party, (C) do not infringe any intellectual property rights of anyone, and (D) that TNC’s use of the Works will not infringe or violate the rights of any third party, including any rights of privacy or publicity; (iii) Contractor has obtained or will obtain all necessary permissions, authorizations, licenses, and releases for creating and licensing the Works.

[Note: this clause (d) may be deleted without triggering legal review, but if deleted, TNC may be required to credit the Contractor in any and all uses of the Works.]

- d. **Moral Rights and Attribution.** TNC will endeavor to credit Contractor for Works when practicable. Notwithstanding the foregoing, Contractor hereby waives to the maximum extent permissible by law the benefit of any provision of law known as droit moral or moral rights or any similar or analogous law or decision in any country of the world. Contractor further waives any right to attribution, and the Licensed Parties shall have no obligation to publish the Works with visible attribution to Contractor, however, TNC will endeavor to credit all photographs when practicable.
- e. *[Optional]***Exclusivity:** Contractor agrees that Contractor will not use, nor will Contractor authorize or permit any third party to use any of the Works (or any portions thereof) in any manner or media now known or hereafter devised until the expiration of the “**Exclusivity Period**” defined as the period commencing on the effective date of this Contract and ending on date to be determined at the commencement of the shooting period. This clause does not prevent the Contractor from providing services to other clients.
- f. *[Optional-Only include this clause (f) if Contractor insists on some limitation of sublicensing to Corporate Partners.]*
Corporate Partner Use. TNC may work to spread and advance its mission with for-profit companies (“**Corporate Partners**”). TNC may, in its sole discretion, sublicense the Works to one or more Corporate Partner(s). Notwithstanding the license set forth herein, and without any further limitation, Contractor grants the Licensed Parties a worldwide, perpetual, irrevocable, fully paid license to sublicense the Works to the Corporate Partners for the limited purpose to publicly communicate and promote its partnership with TNC on the web, in print, and on social media. No Corporate Partner will be authorized to use the Works for its own commercial use.

[End of Section 11, Option 2]

ARPA Terms and Conditions

1.1. Accounting. Grantee shall maintain for the purposes of this Agreement an accounting system or procedures and practices that conforms to Generally Accepted Accounting Principles. As defined by 2 C.F.R. Part 200, Subpart A, GAAP “has the meaning specified in accounting standards issued by the Government Accounting Standards Board and the Financial Accounting Standards Board.

1.2. Use of Funds. Grantee understands and agrees that the funds disbursed under this award may only be used in compliance with section 603(c) of the Social Security Act (the Act), Treasury’s regulations implementing that section, and guidance issued by Treasury regarding the foregoing.

1.3. Capabilities. Grantee will determine prior to engaging in any project using this assistance that it has the institutional, managerial, and financial capability to ensure proper planning, management, and completion of such project.

1.4. Reporting. The Grantee agrees to comply with any reporting obligations established by Treasury as they relate to this award.

1.5. Maintenance of and Access to Records. Grantee shall maintain records and financial documents sufficient to evidence compliance with section 603(c) of the Act, Treasury’s regulations implementing that section, and guidance issued by Treasury regarding the foregoing. The Treasury Office of the Inspector General and the Government Accountability Office, or their authorized representatives, shall have the right of access to records (electronic and otherwise) of Grantee in order to conduct audits or other investigations. Records shall be maintained by Grantee for a period of five (5) years after all funds have been expended or returned to Treasury, whichever is later.

1.6. Pre-Award Costs. Pre-award costs are allowable only to the extent permitted in 2 C.F.R. § 200.458. Pursuant to the Treasury’s SLFRF FAQ, Section 2.6, the ARPA final rule permits funds to be used to cover costs incurred beginning on March 3, 2021. Pre-award costs shall be allowable subject to the terms and conditions of the Agreement.

1.7. Administrative Costs. Grantee may use funds provided under this award to cover both direct and indirect costs.

1.8. Compliance with Applicable Law and Regulations. Grantee agrees to comply with the requirements of section 603 of the Act, regulations adopted by Treasury pursuant to section 603(f) of the Act, and guidance issued by Treasury regarding the foregoing. Grantee also agrees to comply with all other applicable federal statutes, regulations, and executive orders, and Grantee shall provide for such compliance by other parties in any agreements it enters into with other parties relating to this award. Federal regulations applicable to this award include, without limitation, the following:

1.8.1. Uniform Administrative Requirements, Cost Principles, and Audit Requirements for Federal Awards, 2 C.F.R. Part 200, other than such provisions as Treasury may determine are inapplicable to this Award and subject to such exceptions as may be otherwise provided by Treasury. Subpart F – Audit Requirements of the Uniform Guidance, implementing the Single Audit Act, shall apply to this award.

1.8.2. Universal Identifier and System for Award Management (SAM), 2 C.F.R. Part 25, pursuant to which the award term set forth in Appendix A to 2 C.F.R. Part 25 is hereby incorporated by reference.

1.8.3. Reporting Subaward and Executive Compensation Information, 2 C.F.R. Part 170, pursuant to which the award term set forth in Appendix A to 2 C.F.R. Part 170 is hereby incorporated by reference.

1.8.4. OMB Guidelines to Agencies on Governmentwide Debarment and Suspension (Nonprocurement), 2 C.F.R. Part 180, including the requirement to include a term or condition in all lower tier covered transactions (contracts and subcontracts described in 2 C.F.R. Part 180, subpart B) that the award is subject to 2 C.F.R. Part 180 and Treasury's implementing regulation at 31 C.F.R. Part 19.

1.8.5. Grantee Integrity and Performance Matters, pursuant to which the award term set forth in 2 C.F.R. Part 200, Appendix XII to Part 200 is hereby incorporated by reference.

1.8.6. Governmentwide Requirements for Drug-Free Workplace, 31 C.F.R. Part 20.

1.8.7. New Restrictions on Lobbying, 31 C.F.R. Part 21.

1.8.8. Generally applicable federal environmental laws and regulations.

1.9. Statutes and regulations prohibiting discrimination applicable to this award include, without limitation, the following:

1.9.1. Title VI of the Civil Rights Act of 1964 (42 U.S.C. §§ 2000d et seq.) and Treasury's implementing regulations at 31 C.F.R. Part 22, which prohibit discrimination on the basis of race, color, or national origin under programs or activities receiving federal financial assistance.

1.9.2. Section 504 of the Rehabilitation Act of 1973, as amended (29 U.S.C. § 794), which prohibits discrimination on the basis of disability under any program or activity receiving federal financial assistance;

1.9.3. The Age Discrimination Act of 1975, as amended (42 U.S.C. §§ 6101 et seq.), and Treasury's implementing regulations at 31 C.F.R. Part 23, which prohibit discrimination on the basis of age in programs or activities receiving federal financial assistance;

1.9.4. Title II of the Americans with Disabilities Act of 1990, as amended (42 U.S.C. §§ 12101 et seq.), which prohibits discrimination on the basis of disability under programs, activities, and services provided or made available by state and local governments or instrumentalities or agencies thereto; and

1.9.5. The Hatch Act (5 U.S.C. §§ 1501-1508 and 7324-7328), which limit certain political activities of State or local government employees whose principal employment is in connection with an activity financed in whole or in part by this federal assistance.

1.10. Remedial Actions. In the event of Grantee's noncompliance with section 603 of the Act, other applicable laws, Treasury's implementing regulations, guidance, or any reporting or other program requirements, Treasury may impose additional conditions on the receipt of a subsequent tranche of future award funds, if any, or take other available remedies as set forth in 2 C.F.R. § 200.339. In the case of a violation of section 603(c) of the Act regarding the use of funds, previous payments shall be subject to recoupment as provided in section 603(e) of the Act.

1.11. False Statements. Grantee understands that making false statements or claims in connection with this award is a violation of federal law and may result in criminal, civil, or administrative sanctions, including fines, imprisonment, civil damages and penalties, debarment from participating in federal awards or contracts, and/or any other remedy available by law.

1.12. Publications. Any publications produced with funds from this award must display the following language: "This project [is being] [was] supported, in whole or in part, by federal award number [enter project FAIN] awarded to [name of Grantee] by the U.S. Department of the Treasury."

1.13. Debts Owed the Federal Government. Any funds paid to Grantee: (1) in excess of the amount to which Grantee is finally determined to be authorized to retain under the terms of this award; (2) that are determined by the Treasury Office of Inspector General to have been misused; or (3) that are determined by Treasury to be subject to a repayment obligation pursuant to section 603(e) of the Act and have not been repaid by Grantee shall constitute a debt to the federal government. Any debts determined to be owed the federal government must be paid promptly by Grantee. A debt is delinquent if it has not been paid by the date specified in Treasury's initial written demand for payment, unless other satisfactory arrangements have been made or if the Grantee knowingly or improperly retains funds that are a debt as defined in paragraph 14(a). Treasury will take any actions available to it to collect such a debt.

1.14. Disclaimer. The United States expressly disclaims all responsibility or liability to Grantee or third persons for the actions of Grantee or third persons resulting in death, bodily injury,

property damages, or any other losses resulting in any way from the performance of this award or any other losses resulting in any way from the performance of this award or any contract, or subcontract under this award. The acceptance of this award by Grantee does not in any way establish an agency relationship between the United States and Grantee.

1.15. Protections for Whistleblowers. In accordance with 41 U.S.C. § 4712, Grantee may not discharge, demote, or otherwise discriminate against an employee in reprisal for disclosing to any of the list of persons or entities provided below, information that the employee reasonably believes is evidence of gross mismanagement of a federal contract or grant, a gross waste of federal funds, an abuse of authority relating to a federal contract or grant, a substantial and specific danger to public health or safety, or a violation of law, rule, or regulation related to a federal contract (including the competition for or negotiation of a contract) or grant. The list of persons and entities referenced in the paragraph above includes the following:

1.15.1. A member of Congress or a representative of a committee of Congress.

1.15.2. An Inspector General.

1.15.3. The Government Accountability Office.

1.15.4. A Treasury employee responsible for contract or grant oversight or management. An authorized official of the Department of Justice or other law enforcement agency;

1.15.5. A court or grand jury; or

1.15.6. A management official or other employee of Grantee, contractor, or subcontractor who has the responsibility to investigate, discover, or address misconduct.

1.15.7. Grantee shall inform its employees in writing of the rights and remedies provided under this section, in the predominant native language of the workforce.

1.16. Increasing Seat Belt Use in the United States. Pursuant to Executive Order 13043, 62 FR 19217 (Apr. 18, 1997), Grantee should encourage its contractors to adopt and enforce on-the-job seat belt policies and programs for their employees when operating company-owned, rented or personally owned vehicles.

1.17. Reducing Text Messaging While Driving. Pursuant to Executive Order 13513, 74 FR 51225 (Oct. 6, 2009), Grantee should encourage its employees, subrecipients, and contractors to adopt and enforce policies that ban text messaging while driving, and Grantee should establish workplace safety policies to decrease accidents caused by distracted drivers.

July 18, 2023

Forced Labor of Ethnic Uyghurs Ban

Please note that if any of the following apply to the Contractor, then the Contractor shall select the "Exempt Contractor" option below:

- Contractor is a sole proprietorship;
- Contractor has fewer than ten (10) employees; OR
- Contractor is a non-profit organization.

Pursuant to A.R.S. § 35-394, written certification is required to show that the company entering into a contract with a public entity does not use the forced labor, or use any contractors, subcontractors or suppliers that use the forced labor or any goods or services produced by the forced labor or any goods or services produced by the forced labor, of ethnic Uyghurs in the People's Republic of China.

Under A.R.S. § 35-394:

1. "Company" means an organization, association, corporation, partnership, joint venture, limited partnership, limited liability partnership, limited liability company or other entity or business association, including a wholly owned subsidiary, majority-owned subsidiary, parent company or affiliate, that engages in for-profit activity and that has ten or more full-time employees.
2. "Public entity" means this State, a political subdivision of this State or an agency, board, commission or department of this State or a political subdivision of this State.

In compliance with A.R.S. § 35-394, all Contractors must select one of the following:

- Company **does not** use, and agrees not to use during the term of the contract, any of the following:
 - Forced labor of ethnic Uyghurs in the People's Republic of China;
 - Any goods or services produced by the forced labor of ethnic Uyghurs in the People's Republic of China; or
 - Any Contractors, Subcontractors, or suppliers that use the forced labor or any goods or services produced by the forced labor of ethnic Uyghurs in the People's Republic of China.
- The Company **does** participate in the use of Forced Uyghurs Labor as described in A.R.S. § 35-394.
- Exempt Contractor: Select all statements that apply to the Contractor:**
 - Contractor is a sole proprietorship;
 - Contractor has fewer than ten (10) employees; and/or
 - Contractor is a non-profit organization.

Company name

Signature of person authorized to sign

Address

Printed name and Title

City, State, ZIP

Contact email address

Contact phone number

July 18, 2023

Boycott of Israel Disclosure

Please note that if any of the following apply to this Solicitation, Contract, or Contractor, then the Offeror shall select the "Exempt Solicitation, Contract, or Contractor" option below:

- The Solicitation or Contract has an estimated value of less than \$100,000;
- Contractor is a sole proprietorship;
- Contractor has fewer than ten (10) employees; or
- Contractor is a non-profit organization.

Pursuant to A.R.S. § 35-393.01, public entities are prohibited from entering into contracts "unless the contract includes a written certification that the company is not currently engaged in, and agrees for the duration of the contract to not engage in, a boycott of Materials or Services from Israel."

Under A.R.S. § 35-393:

1. "Boycott" means engaging in a refusal to deal, terminating business activities or performing other actions that are intended to limit commercial relations with entities doing business in Israel or in territories controlled by Israel, if those actions are taken either:

(a) Based in part on the fact that the entity does business in Israel or in territories controlled by Israel.

(b) In a manner that discriminates on the basis of nationality, national origin or religion and that is not based on a valid business reason.

2. "Company" means an organization, association, corporation, partnership, joint venture, limited partnership, limited liability partnership, limited liability company or other entity or business association, including a wholly owned subsidiary, majority-owned subsidiary, parent company or affiliate, that engages in for-profit activity and that has ten or more full-time employees.

...

5. "Public entity": (a) Means this State, a political subdivision of this State or an agency, board, commission or department of this State or a political subdivision of this State. (b) Includes the universities under the jurisdiction of the Arizona board of regents and community college districts as defined in section 15-1401.

The certification below does not include boycotts prohibited by 50 United States Code Section 4842 or a regulation issued pursuant to that section. See A.R.S. § 35-393.03.

In compliance with A.R.S. § 35-393 *et seq.*, all Offerors must select one of the following:

- The Company submitting this Offer **does not** participate in, and agrees not to participate in during the term of the contract, a boycott of Israel in accordance with A.R.S. § 35-393 *et seq.* I understand that my entire response will become a public record in accordance with A.A.C. R2-7-C317;
- The Company submitting this Offer **does** participate in a boycott of Israel as described in A.R.S. § 35-393 *et seq.*; or
- Exempt Solicitation, Contract, or Contractor.** Indicate which of the following statements applies to this Contract (may be more than one):
 - Solicitation or Contract has an estimated value of less than \$100,000;
 - Contractor is a sole proprietorship;
 - Contractor has fewer than ten (10) employees; or
 - Contractor is a non-profit organization.

Company name

Signature of person authorized to sign

Address

Printed name and Title

City, State, ZIP

Contact email address

Contact phone number